

# Technical Data

## AR-SERIES



NEW Heat Max Water Source Heat Pump Water Heaters

Technical data		AR-40WTP HX	AR-80WTP HX	AR-160WTP HX
*Heating Capacity	kW	40.0	80.0	160.0
*Cooling Capacity	kW	30.0	60.0	120.0
*Power Input	kW	8.5	17.0	34.0
*COP	W	4.71	4.71	4.71
*EER	W	3.53	3.53	3.53
**Heating Capacity	kW	34.4	68.5	137.6
**Cooling Capacity	kW	26.0	52.1	104.1
**Power Input	kW	8.0	18.0	32.0
**COP	W	4.30	4.30	4.30
**EER	W	3.25	3.25	3.25
Max. Power Input	kW	14.8	29.2	58.4
Max. Running Current	A	27	54	108
Power Supply	V/Ph/Hz	380V~415V/3N~/50Hz		
Compressor Type	/	Copeland ZW150KBE-TFP-522 Scroll Compressor		
Compressor Quantity	/	1	2	4
*Evaporator	Type	PHNIX Patented Tube in Shell Heat Exchanger		
	Water Flow(m <sup>3</sup> /h)	4.5	9.0	18.0
	Water pressure drop(kPa)	45.0	40.0	37.0
	Water Connection	DN40	DN65	DN80
*Condenser	Type	PHNIX Patented Tube in Shell Heat Exchanger		
	Water Flow(m <sup>3</sup> /h)	6.0	12.0	24.0
	Water pressure drop(kPa)	75.0	70.0	66.0
	Water Connection	DN40	DN65	DN80
Noise	dB(A)	65.0	68	69
Refrigerant	/	R134a		
Controller	/	PHNIX Controller		
Display	/	5 Inch Colorful Touch Display		
Max.Outlet Water Temp.	°C	80		
Cabinet	/	Eco-friendly Galvanized Metal/Stainless Steel for option		
Net Weight	kg	202	441	836
Net Dimensions(L/W/H)	mm	1030*640*730	1172*900*1365	1600*1130*1500
Shipping Dimensions(L/W/H)	mm	1130*710*910	1360*960*1520	1790*1210*1670

\*Testing Condition Evaporator Side inlet/outlet:25/20°C; Condenser Side inlet/outlet:50/55°C

\*\*Testing Condition Evaporator Side inlet/outlet:20/15°C; Condenser Side inlet/outlet: 50/55°C

# Dimensions AR- SERIES

## AR-40WTP HX MT

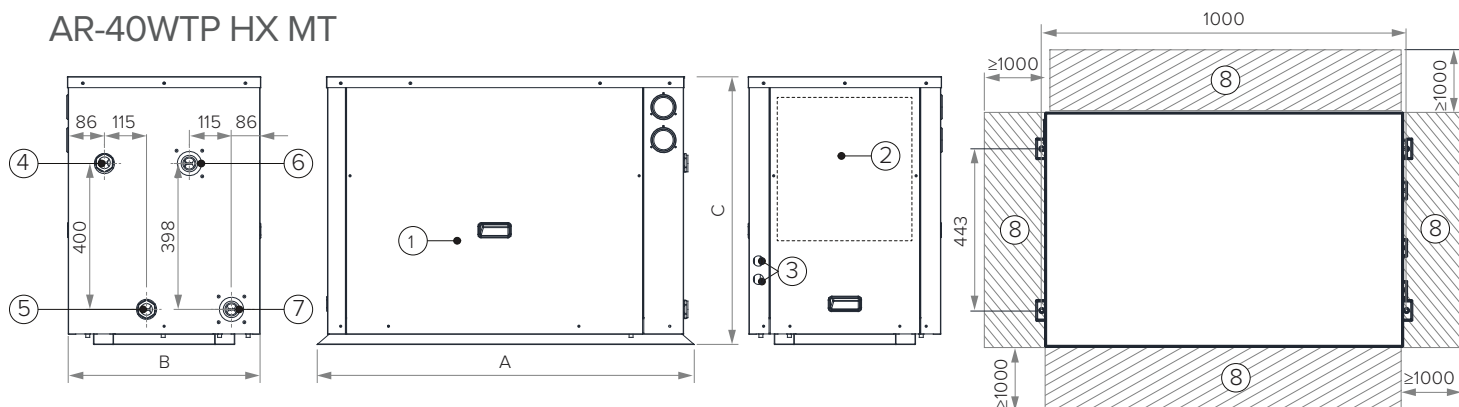

## AR-80WTP HX MT

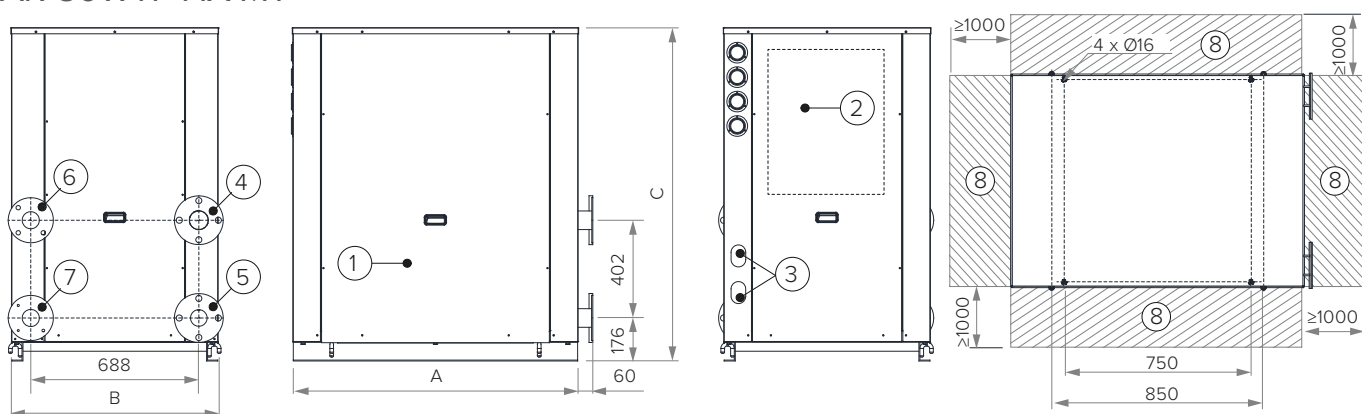

## AR-160WTP HX MT

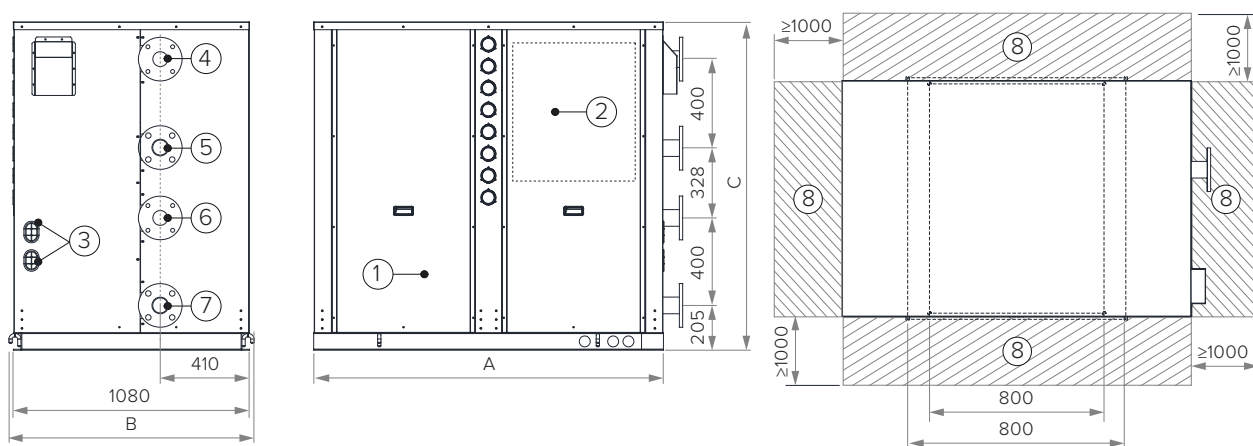

- 1. Compressor area
- 2. Electrical panel/box  
(LED Remote inside the cover)
- 3. Power input
- 4. Heat water outlet
- 5. Heat water inlet
- 6. Cold water inlet
- 7. Cold water outlet
- 8. Clearances

### AR- SERIES - COMMERCIAL AIR TO WATER

### AR-40WTP HX MT

### AR-80WTP HX MT

### AR-160WTP HX MT

Size		AR-40WTP HX MT	AR-80WTP HX MT	AR-160WTP HX MT
Length (A)	mm	973	1172	1600
Width (B)	mm	524	900	1130
Height (C)	mm	730	1365	1500